

# AGLP-4 Parallel Gripper

## T-Slot Bearing Series, Low Profile

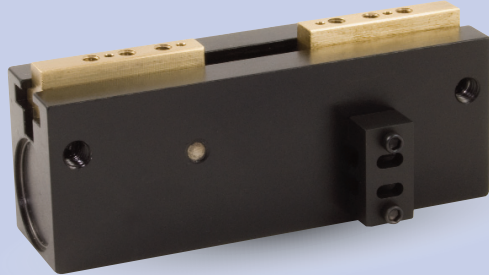

### FEATURES AND BENEFITS

- Jaws are T-Slot bearing supported to prevent jaw breakage and offer superior load bearing performance.
- Rugged rack and pinion synchronizing.
- High gripping force to weight ratio.
- Compact design with long stroke.
- True parallel jaw motion for easy tooling.
- Units are permanently lubricated for non-lube air operation, allowing for compliance with OSHA regulations.
- Hall effect sensors are available to monitor open and closed position of the jaws.
- AGLP is fully field repairable for cost savings and minimum down time

### SPECIFICATIONS

**Design:** Parallel, Double Acting, Synchronized Jaws

**Stroke:** 1.00 in [25.4 mm]

**Gripping Force @ 80 PSI [5.5 BAR]**

Closing: 14 lbs [62 N]  
Opening: 14 lbs [62 N]

**Time:**

Close: 0.12 sec [0.12 sec]  
Open: 0.12 sec [0.12 sec]

**Pressure Range:**

Low/High 10-120 PSI [.7-7 BAR]

**Temperature Range:**

Low/High -20°/180°F [-28°/80°C]

**Side Play:** ± 0.001 [.03 mm]

**Loading Capacity:**

	Static	Dynamic
Max Tensile T	120 lbs [533 N]	40 lbs [177 N]
Max Compressive C	120 lbs [533 N]	40 lbs [177 N]
Max Moment $M_x$	75 in/lb [8.5 Nm]	25 in/lb [2.8 Nm]
Max Moment $M_y$	100 in/lb [11.3 Nm]	35 in/lb [3.9 Nm]
Max Moment $M_z$	75 in/lb [8.5 Nm]	25 in/lb [2.8 Nm]

**Material:** High Strength, Hard Coated aluminum bronze alloys, Steel

**Weight:** 5 oz [142 g]

**Piston Diameter:** 0.700 in [17.7 mm]

### HOLDING FORCES CHART

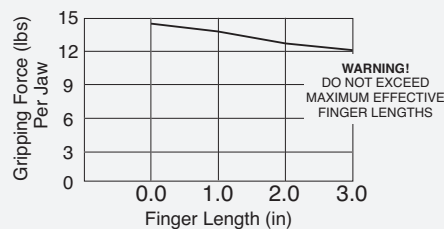

**WARNING!** Do not exceed tooling jaw length. See Chart above.

### LOADING INFORMATION

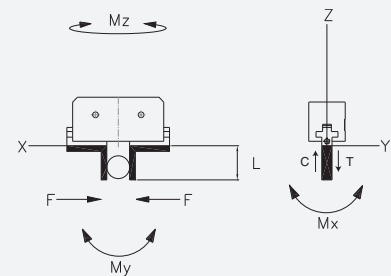

**LOOK!** More Technical specifications for sensors on "Sensors Accessories" page.

### HOW TO ORDER

When ordering, please specify: Design/Model Number and Options.

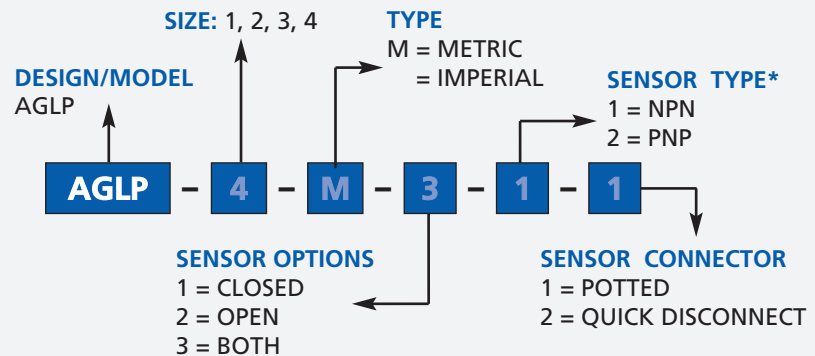

\* NOTE: Hall Effect 4mm dia., 5-24 VDC, 22 mA and comes with 2 meter cable or quick disc.

Sensor Part # SHN01, SHNQ3, SHP01, SHPQ3

January 2009 - PATENTED Made in the USA

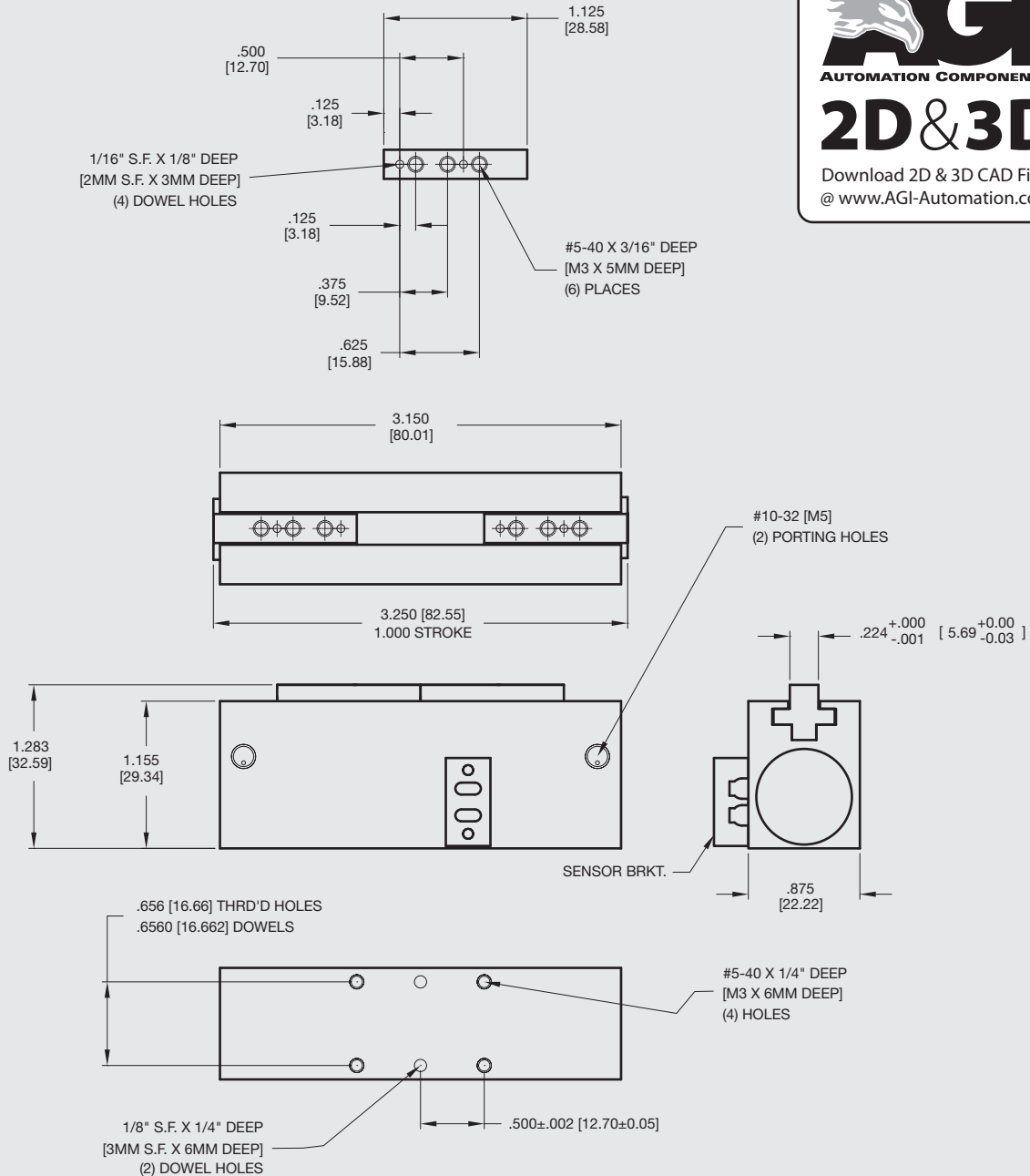

**Unless noted, all tolerances are as indicated here:**



All Dowel Holes are SF (Slip Fit) Locational Tolerance ± .0005" [0.13mm]



Metric Threads Course Pitch

**Imperial:**  
Inch 0.00 = ±.01  
0.000 = ±.005  
0.0000 = ±.0005

**Metric:** [0.] = ±.25  
[0.0] = ±.13  
[0.00] = ±.013