

AGE-3 Feed Escapement

Built-in Air Cylinder

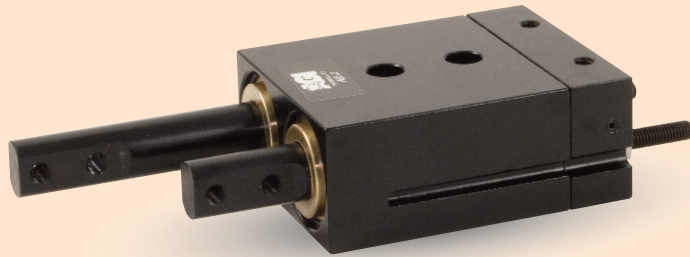

FEATURES AND BENEFITS

- Compact, Long Stroke Escapements made for separating and isolating individual parts from tracks, vibratory feeders or conveyors.
- Internal sequencing and cross porting make sure both rods are extended before either rod can retract, ensuring positive part feeding.
- Easy part jam clearing due to internal back pressure cross port design, this allows both rods to be retracted with the air off.
- Piston seals are U-CUP type for long service life.
- Hall effect sensors are available to monitor stroke position at any point in the stroke.
- Adjustable stroke on retraction.

SPECIFICATIONS

Design: Double Acting, Internal Sequencing

Stroke 1.56 in 39 mm
Option: Adjustable Stroke

Thrust Force: @80 psi [5.5 BAR]

Extend Force: 60 lb [270 Kg]

Retract Force: 52 lb [231 Kg]

Time: .35 Sec [.35 sec]

Pressure Range:

Low/High 20-120 PSI [1.4-8 BAR]

Temperature Range:

Low/High -20°/180°F [-28°/80°C]

Side Play:

± .002 in ± 0.06 mm

Loading Capacity:

	Static	Dynamic
Max Moment M_x	230 lbs [24 Nm]	24 lbs [2.6 Nm]
Max Moment M_y	230 lbs [24 Nm]	24 lbs [2.6 Nm]
Max Moment M_z	230 lbs [24 Nm]	24 lbs [2.6 Nm]

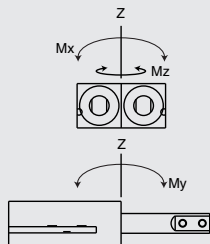

Material: High Strength, Aluminum Alloys, Bronze

Weight: 1 lb [0.45 Kg]

Piston Diameter: 1 in [25 mm]

TYPICAL OPERATION:

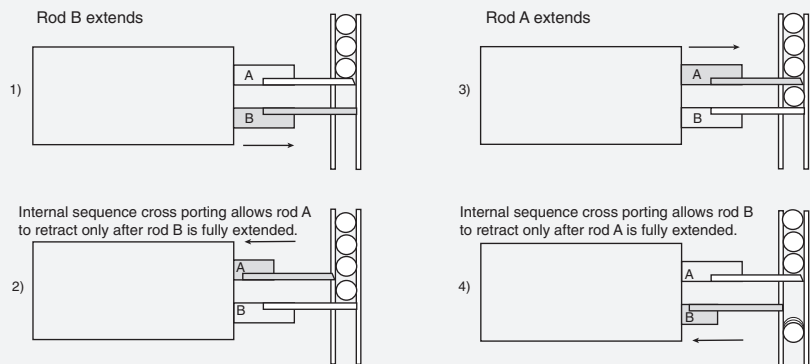

AGI Escapements are two double acting cylinders that are cross ported and internally sequenced. A four way, two position valve is needed to operate this escapement. ***Rods A and B must be allowed to extend to the end of it's stroke to operate.**

HOW TO ORDER

When ordering, please specify:
Design/Model Number and Options.

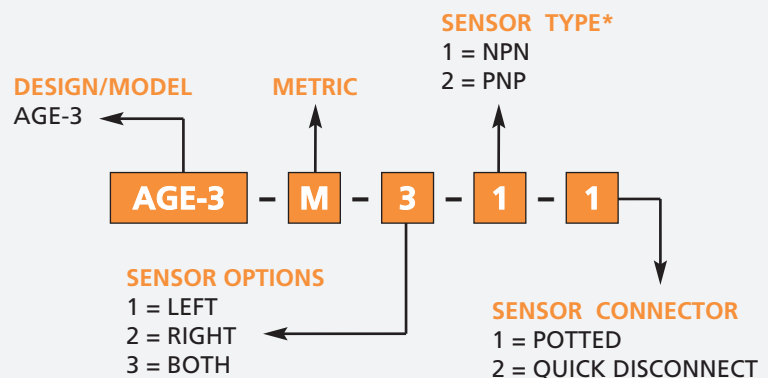

* NOTE: Hall Effect Sensors are hard wired with a 20" pigtail.

Sensor Part # SHN01, SHP01, SHNQ3, SHPQ3

January 2009 - PATENTED Made in the USA

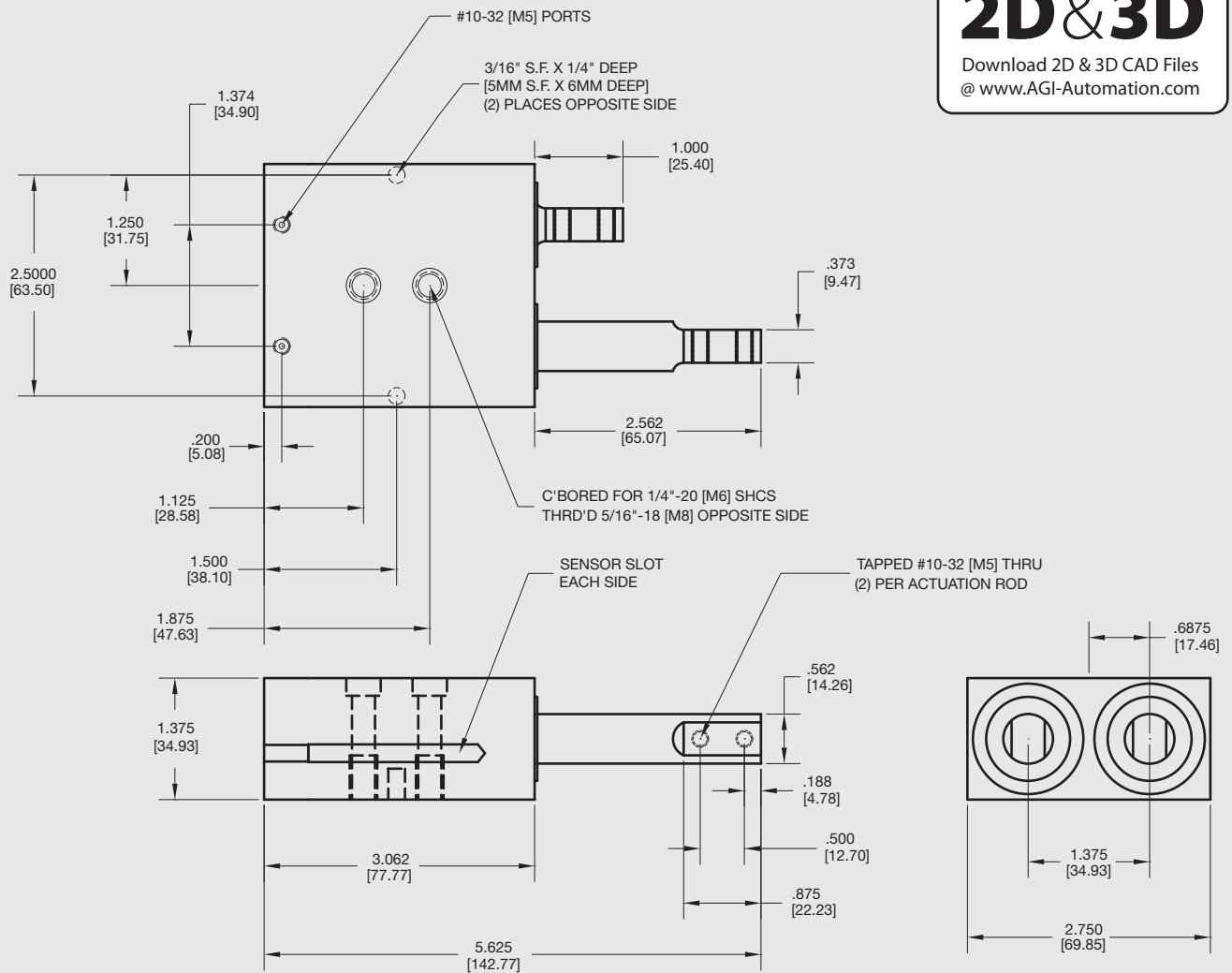

Unless noted, all tolerances are as indicated here:



All Dowel Holes are SF (Slip Fit) Locational Tolerance $\pm .0005"$ [.013mm]



Metric Threads Course Pitch

Imperial:
Inch

0.00 = ± 0.1
0.000 = ± 0.005
0.0000 = ± 0.0005

Metric:
[mm]
[0.] = ± 0.25
[0.0] = ± 0.13
[0.00] = ± 0.13