



# AGMS-1-2 Feed Escapement

## Single Finger



### FEATURES AND BENEFITS

- Compact, Long Stroke Escapements made for separating and isolating individual parts from tracks, vibratory feeders or conveyors.
- T-Slot bearing support for the carriage and end plate offers superior load bearing performance throughout the stroke.
- Standard built-in stroke adjustment and stroke lock for precise, repetitive operation.
- Compact, lightweight unit with built-in cylinder.
- Piston seals are U-CUP type for long service life.
- Hall Effect sensors are available to monitor stroke position.
- Multiple mounting surfaces on the body and endplate with threaded and counterbored holes for easy mounting choices.
- Adjustable stroke on extend and retract.

### SPECIFICATIONS

**Design:** Built-in air cylinder  
T-slot slide

**Stroke (Adjustable):** 1 inch [25.4 mm]

**Thrust Force @ 80 PSI [5.5 BAR]**

Extended: 15 lbs [66.7 N]  
Retract: 13 lbs [57.8 N]

**Recommended Speed:**

2-12 in/sec  
[0.5-.3m/sec]

**Pressure Range:**

Low/High 20-120 PSI [1.4-8 BAR]

**Temperature Range:**

Low/High -20°/150°F [-28°/80°C]

**Side Play:**

± 0.001 [0.03 mm]

**Maximum Payload:**

7 lbs [3.2 kg]

**Material:** High Strength, Aluminum Alloys, Bronze

**Weight:**

3.2 oz [90 g]

**Piston Diameter:**

.50 in [12.7 mm]

January 2008 - PATENTED Made in the USA

### MAXIMUM FORCES & MOMENTS

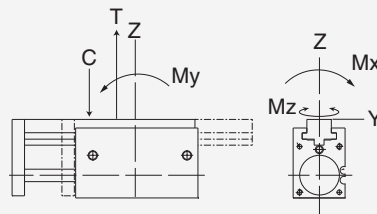

	Static	Dynamic
Max Tensile T	75 lbs [333 N]	32 lbs [142 N]
Max Compressive C	75 lbs [333 N]	32 lbs [142 N]
Max Moment $M_x$	60 in/lb [6.7 Nm]	30 in/lb [3.4 Nm]
Max Moment $M_y$	60 in/lb [6.7 Nm]	30 in/lb [3.4 Nm]
Max Moment $M_z$	60 in/lb [6.7 Nm]	30 in/lb [3.4 Nm]

### HOW TO ORDER

When ordering, please specify:  
Design/Model Number and Options.

**DESIGN/MODEL**

- AGMS-1-1
- AGMS-1-2
- AGMS-1-3
- AGMS-1-4

**METRIC**

AGMS-1-2

**SENSOR TYPE**

- 1 = NPN
- 2 = PNP

**SENSOR CONNECTOR**

- 1 = POTTED
- 2 = QUICK DISCONNECT
- 3 = QUICK DISCONNECT WITH RIGHT ANGLE

**SENSOR OPTIONS\***

- 1 = LEFT
- 2 = RIGHT
- 3 = BOTH

M - 3 - 1 - 1

\* NOTE: Hall Effect sensors – Potted or Quick disconnect.

Sensor Part # SHN01, SHP01, SHNQ3, SHPQ3

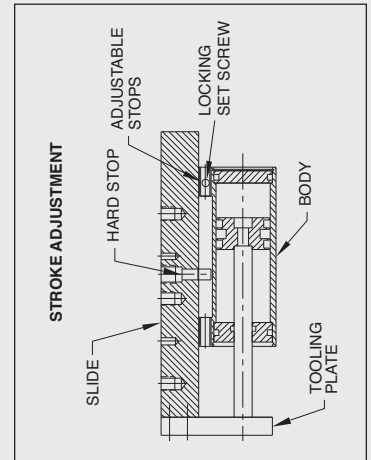
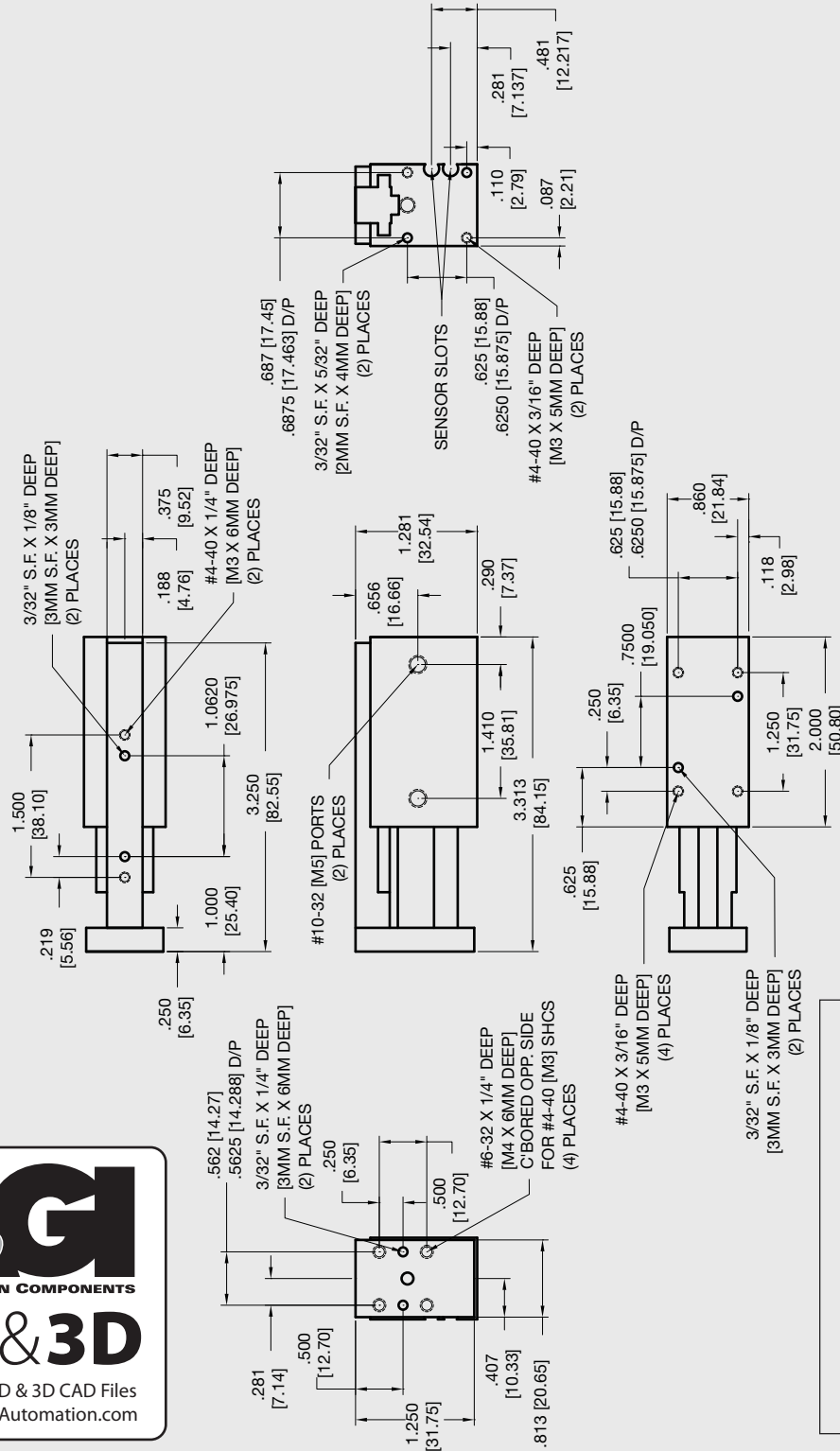

**Unless noted, all tolerances are as indicated here:**



All Dowel Holes are SF (Slip Fit) Locational Tolerance  $\pm .0005"$  [0.13mm]



Metric Threads  
Course Pitch

**Imperial:**  
Inch  
0.00 =  $\pm .01$   
0.000 =  $\pm .005$   
0.0000 =  $\pm .0005$

**Metric:**  
[0.] =  $\pm .25$   
[0.0] =  $\pm .13$   
[0.00] =  $\pm .013$