

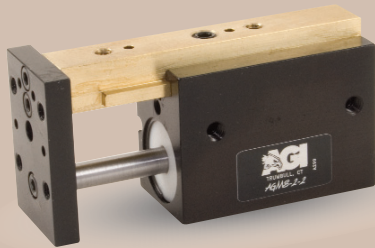

AGMS-2-2 Mini Powered Slide

Built-In Air Cylinder



FEATURES AND BENEFITS

- T-Slot bearing support for the carriage and end plate offers superior load bearing performance throughout the stroke.
- Standard built-in stroke adjustment and stroke lock for precise, repetitive operation.
- Compact, lightweight unit with built-in cylinder.
- Piston seals are U-CUP type for long service life.
- Hall Effect sensors are available to monitor stroke position.
- Multiple mounting surfaces on the body and endplate with threaded and counterbored holes for easy mounting choices.

SPECIFICATIONS

Design: Built-in air cylinder
T-slot slide

Stroke: 1 in [25.4 mm]

Thrust Force @ 80 PSI [5.5 BAR]

Extended: 35 lbs [155 N]
Retract: 33 lbs [146 N]

Recommended Speed:

2-12 in/sec
[0.5-.3m/sec]

Pressure Range:

Low/High 20-120 PSI [1.4-8 BAR]

Temperature Range:

Low/High -20°/150°F [-28°/80°C]

Side Play:

± 0.001 [.03 mm]

Maximum Payload:

13 lbs [5.9 kg]

Material: High Strength, Aluminum Alloys, Bronze

Weight:

5.6 oz [160 g]

Piston Diameter:

.750 in [19 mm]

January 2009 - PATENTED Made in the USA

MAXIMUM FORCES & MOMENTS

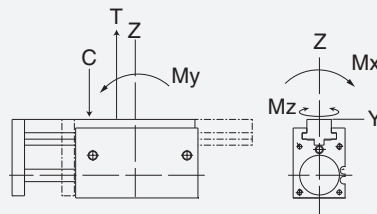

	Static	Dynamic
Max Tensile T	140 lbs [622 N]	60 lbs [266 N]
Max Compressive C	140 lbs [622 N]	60 lbs [266 N]
Max Moment M_x	70 in/lb [8 Nm]	30 in/lb [3.4 Nm]
Max Moment M_y	70 in/lb [8 Nm]	30 in/lb [3.4 Nm]
Max Moment M_z	70 in/lb [8 Nm]	30 in/lb [3.4 Nm]

HOW TO ORDER

When ordering, please specify:
Design/Model Number and Options.

DESIGN/MODEL

- AGMS-2-1
- AGMS-2-2
- AGMS-2-3
- AGMS-2-4

METRIC

AGMS-2-2

SENSOR TYPE

- 1 = NPN
- 2 = PNP

M - 3

SENSOR CONNECTOR

- 1 = POTTED
- 2 = QUICK DISCONNECT
- 3 = QUICK DISCONNECT WITH RIGHT ANGLE

SENSOR OPTIONS*

- 1 = LEFT
- 2 = RIGHT
- 3 = BOTH

* NOTE: Hall Effect sensors are hard wired with 20" pigtail.

Sensor Part # SHN01, SHP01, SHNQ3, SHPQ3

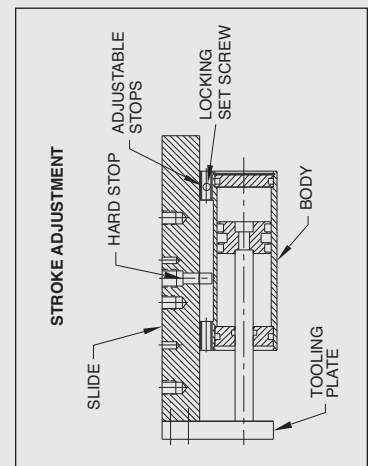
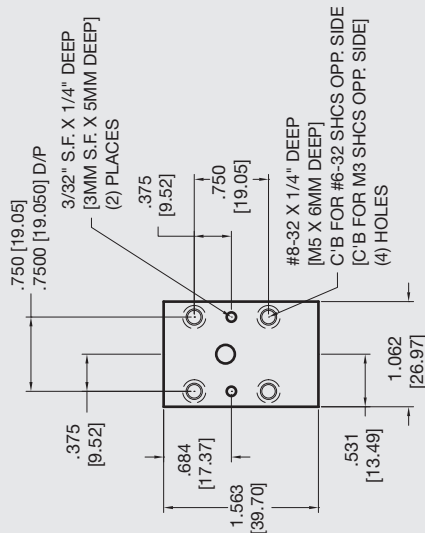
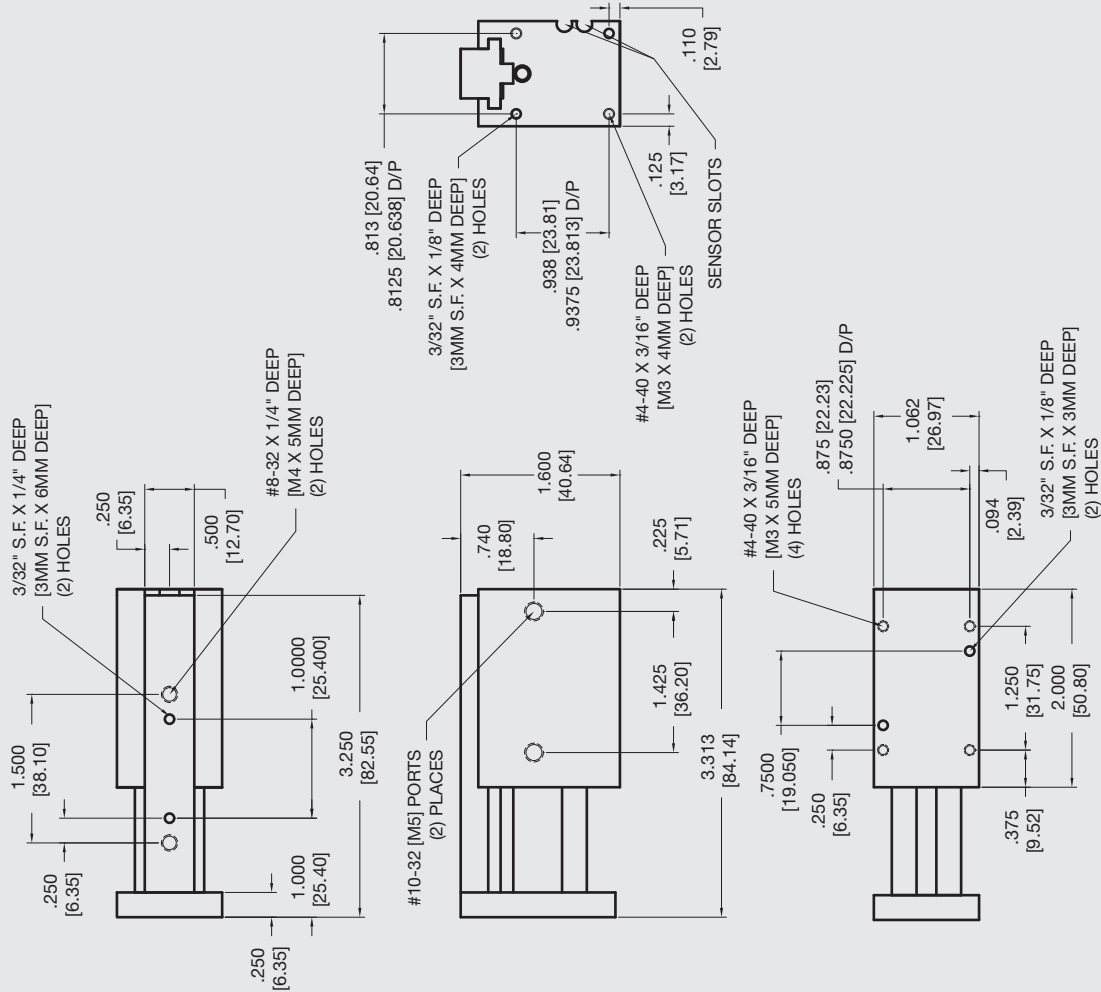

Unless noted, all tolerances are as indicated here:



All Dowel Holes are SF (Slip Fit) Locational Tolerance $\pm .0005"$ [0.13mm]



Metric Threads Course Pitch

Imperial: 0.00 = ± 0.01
Inch 0.000 = ± 0.005
0.0000 = ± 0.0005

Metric: [0.] = ± 0.25
[mm] [0.0] = ± 0.13
[0.00] = ± 0.13