



AGP-8-OR Parallel Gripper

8-Finger Gripper for Placing O-Rings, T-Slot Bearing Series



FEATURES AND BENEFITS

- Jaws are T-Slot bearing supported to prevent jaw breakage and offer superior load bearing performance.
- Spreading jaws and Ejector jaws have independent pistons to provide exact timing of O-ring placement.
- Compact design with long adjustable stroke.
- True parallel jaw motion for easy tooling.
- Hole through center facilitates part seating and ejection.
- Available in Imperial only.

SPECIFICATIONS

Design: Parallel, Double Acting, Synchronized Sealed Jaws

Stroke: Spread 1.10 in. adj. [27.9 mm]
Ejecting 0.55 in [13.9 mm]

Gripping Force Per Jaw @ 80 PSI [5.5 BAR]

Spreading Jaw: 200 lbs [889 N]

Ejector Jaw: 310 lbs [1378 N]

Time:

Close: 0.2 sec [0.2 sec]

Open: 0.2 sec [0.2 sec]

Pressure Range:

Low/High 30-100 PSI [2-7 BAR]

Temperature Range:

Low/High -20°/180°F [-28°/80°C]

Side Play: ± 0.001 [0.03 mm]

Repeatability from center:

±.002 [0.06 mm]

Loading Capacity:

	Static	Dynamic
Max Tensile T	100 lbs [445 N]	30 lbs [130 N]
Max Compressive C	100 lbs [445 N]	30 lbs [130 N]
Max Moment M_x	200 in/lb [22 Nm]	50 in/lb [6 Nm]
Max Moment M_y	230 in/lb [23 Nm]	60 in/lb [6 Nm]
Max Moment M_z	200 in/lb [22 Nm]	50 in/lb [6 Nm]

HOLDING FORCES CHART

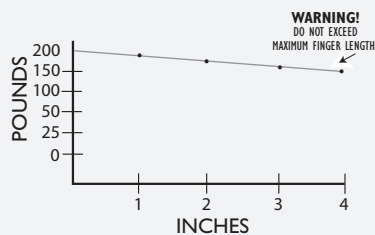

WARNING! Do not exceed tooling jaw length. See Chart above.

LOADING INFORMATION

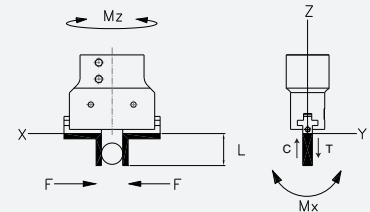

LOOK! More Technical specifications for sensors on "Sensors Accessories" page.

HOW TO ORDER

When ordering, please specify:
Design/Model Number and Options.

DESIGN/MODEL

AGP-6-OR
AGP-8-OR

SENSOR TYPE*

1 = NPN
2 = PNP

AGP-8-OR - 3 - 1 - 1

SENSOR OPTIONS

1 = JAW OPEN
2 = EJECTOR DOWN
3 = BOTH

SENSOR CONNECTOR

1 = POTTED
2 = QUICK DISCONNECT
3 = QUICK DISCONNECT WITH RIGHT ANGLE

* NOTE: Proximity sensors are 4 mm dia., 12-30 VDC, 50 mA and comes with 2 meter cable.

Sensor Part # SNC06, SNQ06, SPC06, SPQ06

AGP-8-OR Parallel Gripper

8-Finger Gripper for Placing O-Rings, T-Slot Bearing Series

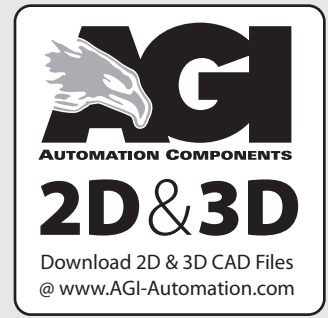
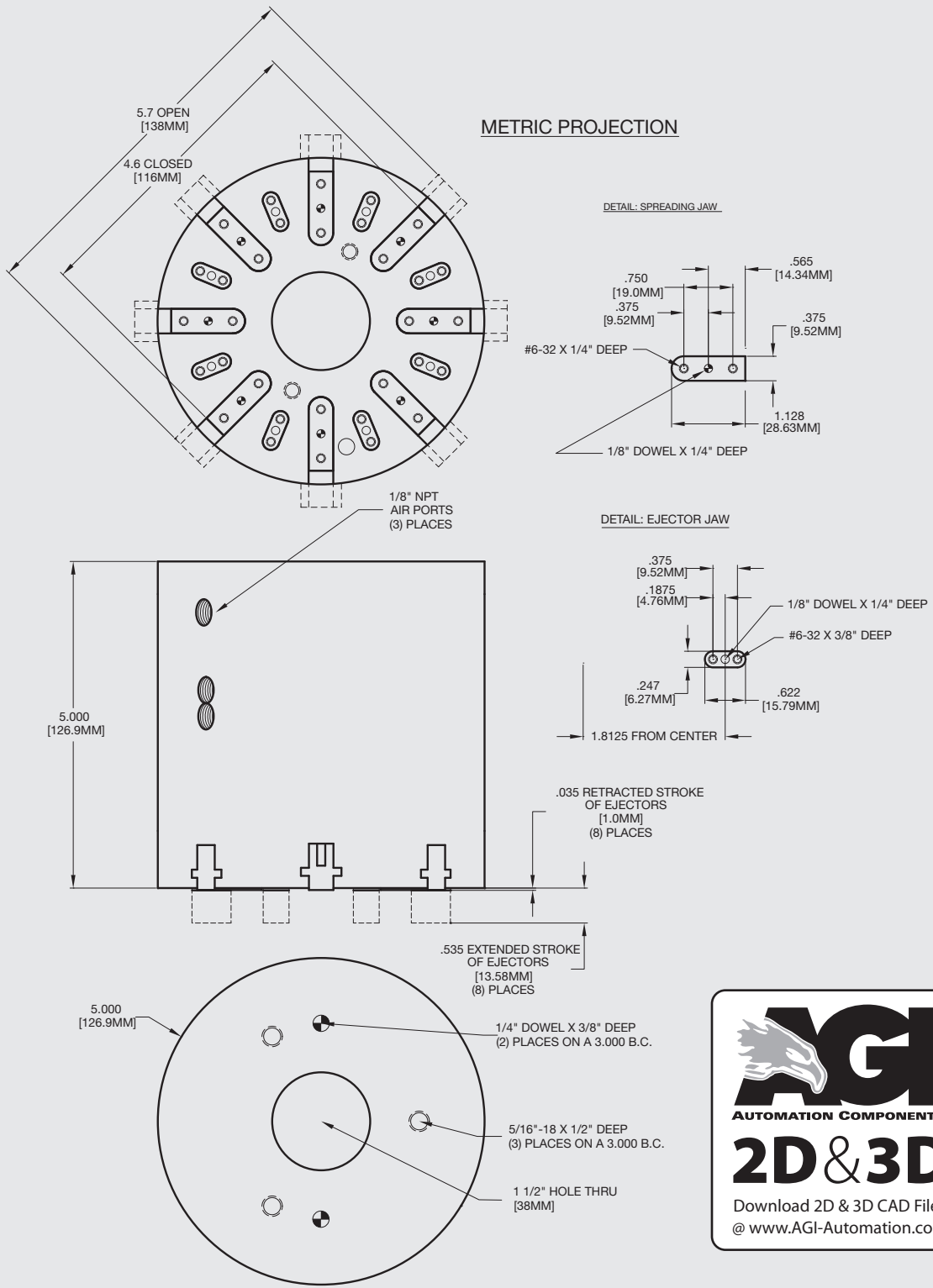

Unless noted, all tolerances are as indicated here:



All Dowel Holes are SF (Slip Fit) Locational Tolerance $\pm .0005"$ [.013mm]



Metric Threads Course Pitch

Imperial:
Inch 0.00 = $\pm .01$
0.000 = $\pm .005$
0.0000 = $\pm .0005$

Metric: [0.] = $\pm .25$
[mm] [0.0] = $\pm .13$
[0.00] = $\pm .013$