

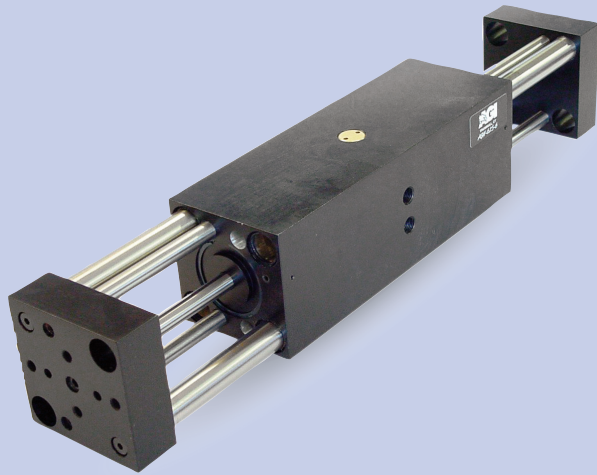

# AGW-625-6 Parallel Gripper

## Wide-Body, Synchronous/Non-Synchronous



### FEATURES AND BENEFITS

- Ultra high gripping force to weight ratio due to four opposing independent pistons that direct power to the jaws.
- True parallel jaw motion for easy tooling.
- Units are permanently lubricated for non-lube air operation, allowing for compliance with OSHA regulations.
- Large jaw support shafts are guided through the full width of the main body.
- Proximity switches are available to monitor open and closed position of the jaws.
- The AGW Series is fully field repairable for cost savings and minimum down time.
- Non-synchronous versions allow the gripper's jaws to comply to the part's centerline versus the gripper's centerline.

### SPECIFICATIONS

**Design:** Parallel, Double Acting, Synchronized Jaws

**Stroke:** 6 in [152.4 mm]

**Gripping Force @ 80 PSI Per Jaw [5.5 BAR]**

Closing: 130 lbs [578 N]

Opening: 132 lbs [587 N]

**Time:**

Close: 0.3 sec [0.3 sec]

Open: 0.3 sec [0.3 sec]

**Pressure Range:**

Low/High 20-120 PSI [1.7-8 BAR]

**Temperature Range:**

Low/High -20°/180°F [-28°/80°C]

**Side Play:**

± 0.001 [.03 mm]

**Repeatability from Center:**

± 0.002 [.06 mm]

**Loading Capacity:**

	Static	Dynamic
Max Tensile T	1300 lbs [5700 N]	150 lbs [667 N]
Max Compressive C	1300 lbs [5700 N]	150 lbs [667 N]

Max Moment  $M_x$  1100 in/lb [124 Nm] 120 in/lb [13.5 Nm]

Max Moment  $M_y$  1500 in/lb [170 Nm] 130 in/lb [14.7 Nm]

Max Moment  $M_z$  1100 in/lb [124 Nm] 120 in/lb [13.5 Nm]

**Material:** High Strength, Hard Coated aluminum bronze alloys, Steel

**Weight:** 9.7 lbs [4.4 kg]

**Piston Diameter:** 1.625 in [41.3 mm]

January 2009 - PATENTED Made in the USA

### HOLDING FORCES CHART

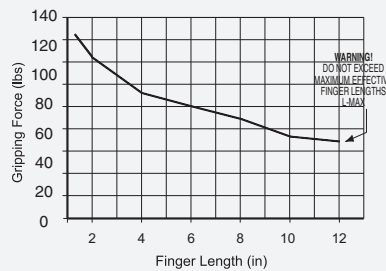

**WARNING!** Do not exceed tooling jaw length. See Chart above.

### LOADING INFORMATION

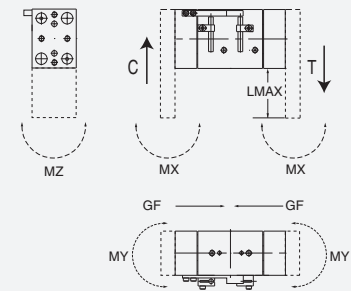

**LOOK!** More Technical specifications for sensors on "Sensors Accessories" page.

### HOW TO ORDER

When ordering, please specify: Design/Model Number and Options.

#### DESIGN/MODEL

- AGW-250
- AGW-375-1
- AGW-375-2
- AGW-375-4
- AGW-500-1
- AGW-500-2
- AGW-500-4
- AGW-625-2
- AGW-625-4
- AGW-625-6

#### SENSOR OPTIONS

- 1 = CLOSED
- 2 = OPEN
- 3 = BOTH

#### SENSOR TYPE\*

- 1 = NPN
- 2 = PNP

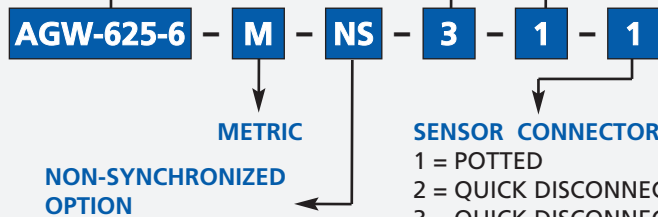

\* NOTE: Proximity 4mm dia., 5-24 VDC, 22 mA and comes with 2 meter cable.

Sensor Part # SNQ04, SNC04, SPC04, SPQ04

# AGW-625-6 Parallel Gripper

## Wide-Body, Synchronous/Non-Synchronous

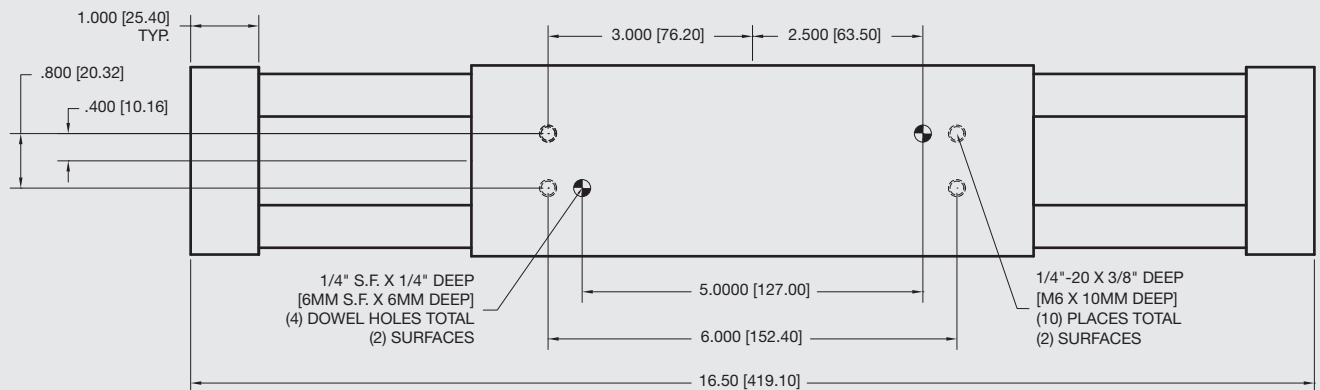
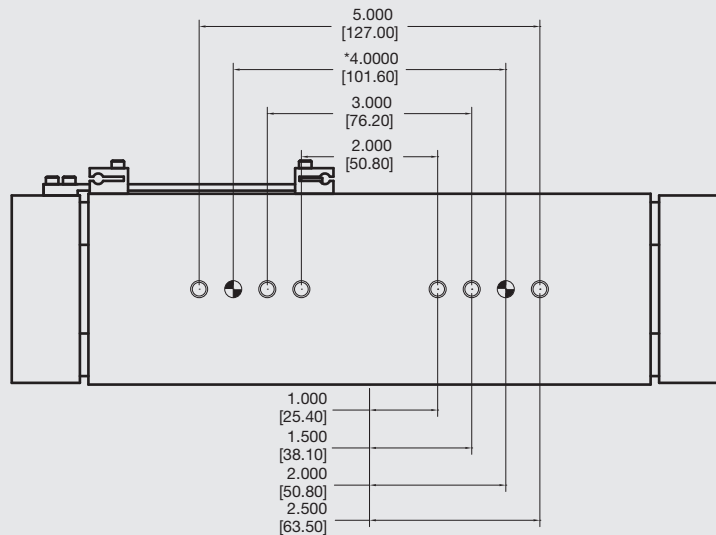
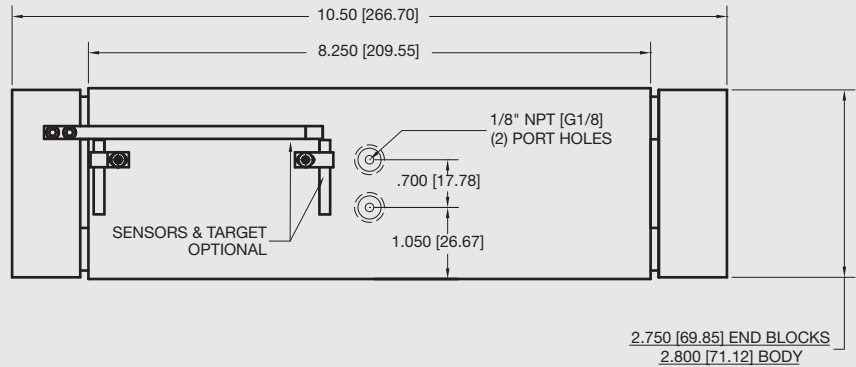
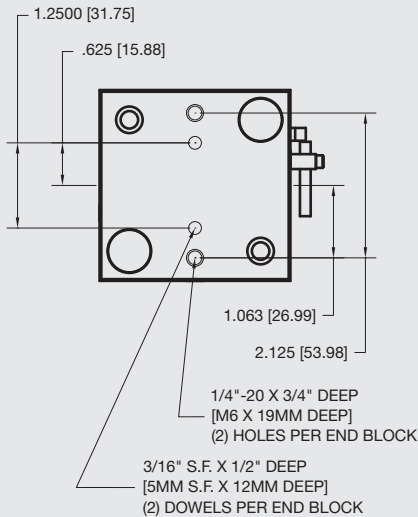

**Unless noted, all tolerances are as indicated here:**



All Dowel Holes are SF (Slip Fit) Locational Tolerance  $\pm .0005$  [0.13mm]



Metric Threads Course Pitch

**Imperial:**  
Inch 0.00 =  $\pm 0.01$   
0.000 =  $\pm 0.005$   
0.0000 =  $\pm 0.0005$

**Metric:**  
[0.] =  $\pm 0.25$   
[0.0] =  $\pm 0.13$   
[0.00] =  $\pm 0.13$