



# AGA-43 Angular Gripper

## 180° Three Jaw



### FEATURES AND BENEFITS

- Grippers provide up to 180° of angular jaw travel allowing the jaws to completely retract from the work area eliminating another required axis of travel.
- High gripping force to weight ratio.
- Compact design with long, adjustable stroke.
- Jaw rotations can be adjusted from 0-90° to allow the gripper to be custom fit to each application.
- Units are permanently lubricated for non-lube air operation, allowing for compliance with OSHA regulation.
- Proximity sensors are available to monitor open and closed position of the jaws.
- AGA is fully field repairable for cost savings and minimum down time.
- The gripper body has two mounting surfaces with dowel pin holes to provide accurate mounting in a variety of positions.

### SPECIFICATIONS

**Design:** 3-Jaw Angular

**Stroke:** 0-180° adjustable

**Gripping Force @ 80 PSI [5.5 BAR]**

Closing: 60 lbs [266 N]  
Opening: 55 lbs [244 N]

**Time:**

Close: 0.4 sec [0.4 sec]  
Open: 0.4 sec [0.4 sec]

**Pressure Range:**

Low/High 10-120 PSI [7-8 BAR]

**Temperature Range:**

Low/High -20°/180°F [-28°/80°C]

**Side Play:** ± 0.001 [.03 mm]

**Repeatability from Center:** ± 0.002 [.06 mm]

**Loading Capacity:**

	Static	Dynamic
Max Tensile T	90 lbs [400 N]	40 lbs [177 N]
Max Compressive C	90 lbs [400 N]	40 lbs [177 N]

Max Moment  $M_x$  150 in/lb [17 Nm] 430 in/lb [4.5 Nm]

Max Moment  $M_y$  180 in/lb [20.3 Nm] 45 in/lb [5 Nm]

Max Moment  $M_z$  150 in/lb [17 Nm] 40 in/lb [4.5 Nm]

**Material:** High Strength, Hard Coated aluminum bronze alloys, Steel

**Weight:** 3.5 lbs [1.6 kg]

**Piston Diameter:** 1.5 in [38 mm]

January 2009 - PATENTED Made in the USA

### HOLDING FORCES CHART

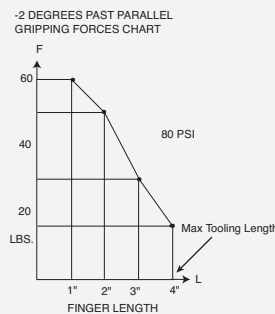

**WARNING!** Do not exceed tooling jaw length. See Chart above.

### LOADING INFORMATION

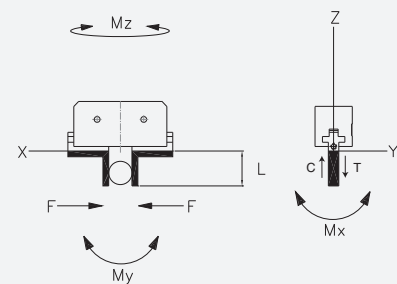

**LOOK!** More Technical specifications for sensors on "Sensors Accessories" page.

### HOW TO ORDER

When ordering, please specify:  
Design/Model Number and Options.

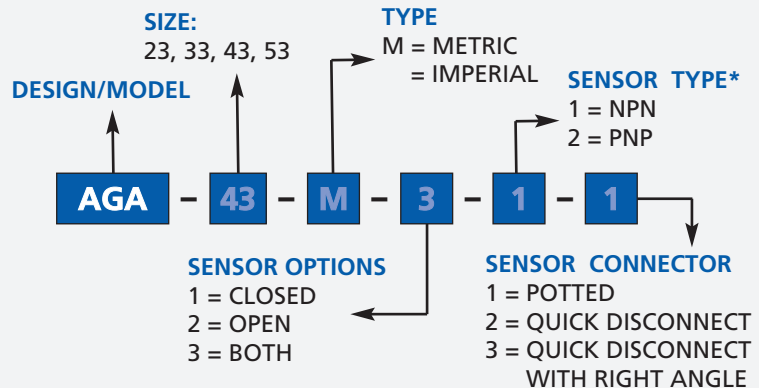

\* NOTE: Hall Effect 4mm dia., 5-24 VDC, 22 mA and comes with 2 meter cable.

Sensor Part # SNQ04, SNC02, SPC02, SPQ04

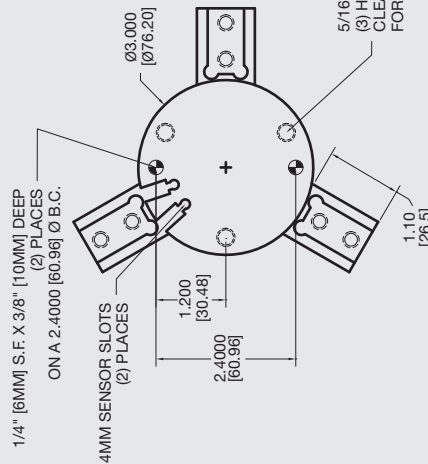
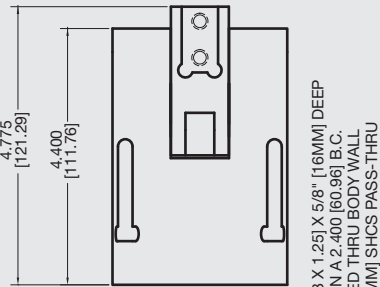
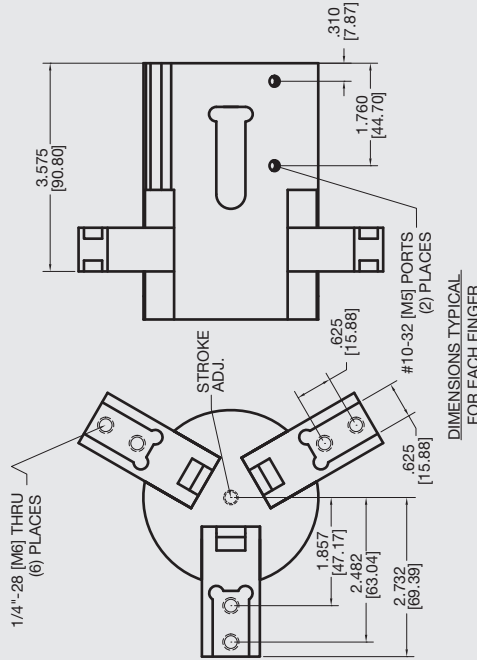

**Unless noted, all tolerances are as indicated here:**



All Dowel Holes are SF (Slip Fit) Locational Tolerance  $\pm .0005"$  [0.13mm]



Metric Threads Course Pitch

**Imperial:**  
Inch 0.00 =  $\pm 0.01$   
0.000 =  $\pm 0.005$   
0.0000 =  $\pm 0.0005$

**Metric:** [0.] =  $\pm 0.25$   
[0.0] =  $\pm 0.13$   
[0.00] =  $\pm 0.13$