

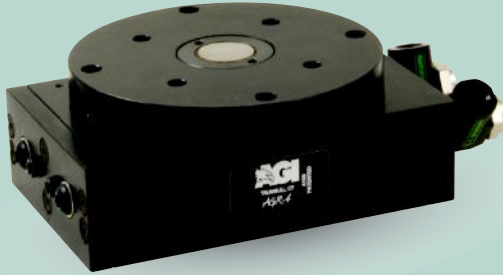

AGR-4 Rotary Actuator

Low Profile, Zero Backlash, Optional Rotary Manifold



FEATURES AND BENEFITS

- Built in adjustable hardstops on output flange stops against a dowel pin imbedded in the body to prevent pinion breakage, and give accurate specific rotation requirements.
- Two large bearings, one on either side of the pinion, provides for steady output flange with high loading capacity.
- Ultra high torque to weight ratio for faster cycle times.
- Compact body design to fit into tight space applications.
- Units are permanently lubricated for non-lube air operation, allowing compliance with OSHA regulations.
- All rotary units have zero backlash at either end of rotation, this keeps the output flange against the hard stop.
- Built in adjustable flow controls allow for maximum cycle times and smooth deceleration.
- Proximity switches are available to monitor end of rotation.
- The AGR unit is fully repairable for cost savings and minimum down time.

SPECIFICATIONS

Design: Rack and Pinion with Flange Hard Stop

Rotation Range: 0°-180° (Adj. +/- 5°)

Payload: 15 lbs central to axis of rotation [6.8 Kg]

Torque:
@80 psi [5.5 BAR] 100 in/lb [11.3 Nm]

Bearing Load:
Dynamic 1390 lbs [6180 N]
Static 2150 lbs [9560 N]

Rotation Time: No load .40 second

Pressure Range:
Low/High 30-120 PSI [2-8 BAR]

Temperature Range:
Low/High -20°/180°F [-28°/80°C]

Backlash: Zero

Accuracy: .001 concentric and perpendicular to axis of rotation

Material: High Strength, Hard Coated Aluminum Alloys, Steel

Weight: 5.0 lb [2.3 kg]

Piston Diameter: (2x) 1.25 in [32 mm]

January 2009 - PATENTED Made in the USA

LOADING INFORMATION

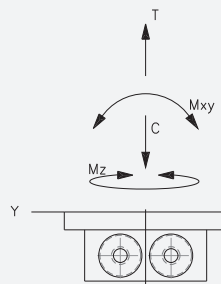

	Static	Dynamic
Max Tensile T	200 lbs [889 N]	40 lbs [177 N]
Max Compressive C	1000 lbs [4448 N]	200 lbs [899 N]
Max Moment M_x	500 in/lb [56.5 Nm]	100 in/lb [11.3 Nm]
Max Moment M_y	500 in/lb [56.5 Nm]	100 in/lb [11.3 Nm]

WARNING! Do not exceed tooling jaw length.

HOW TO ORDER

When ordering, please specify:
Design/Model Number and Options.

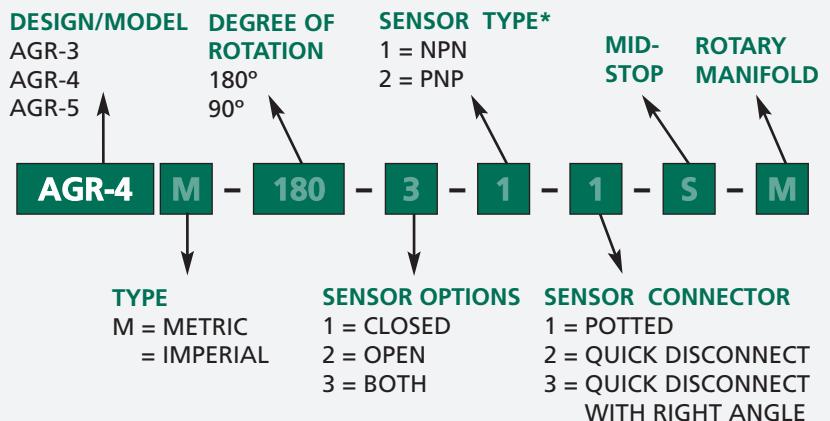

* NOTE: Proximity 4mm dia., 5-24 VDC, 22 mA and comes with 2 meter cable.

Sensor Part # SPC05, SPQ05, SNC05, SNQ05

AGR-4 Rotary Actuator

Low Profile, Zero Backlash, Optional Rotary Manifold

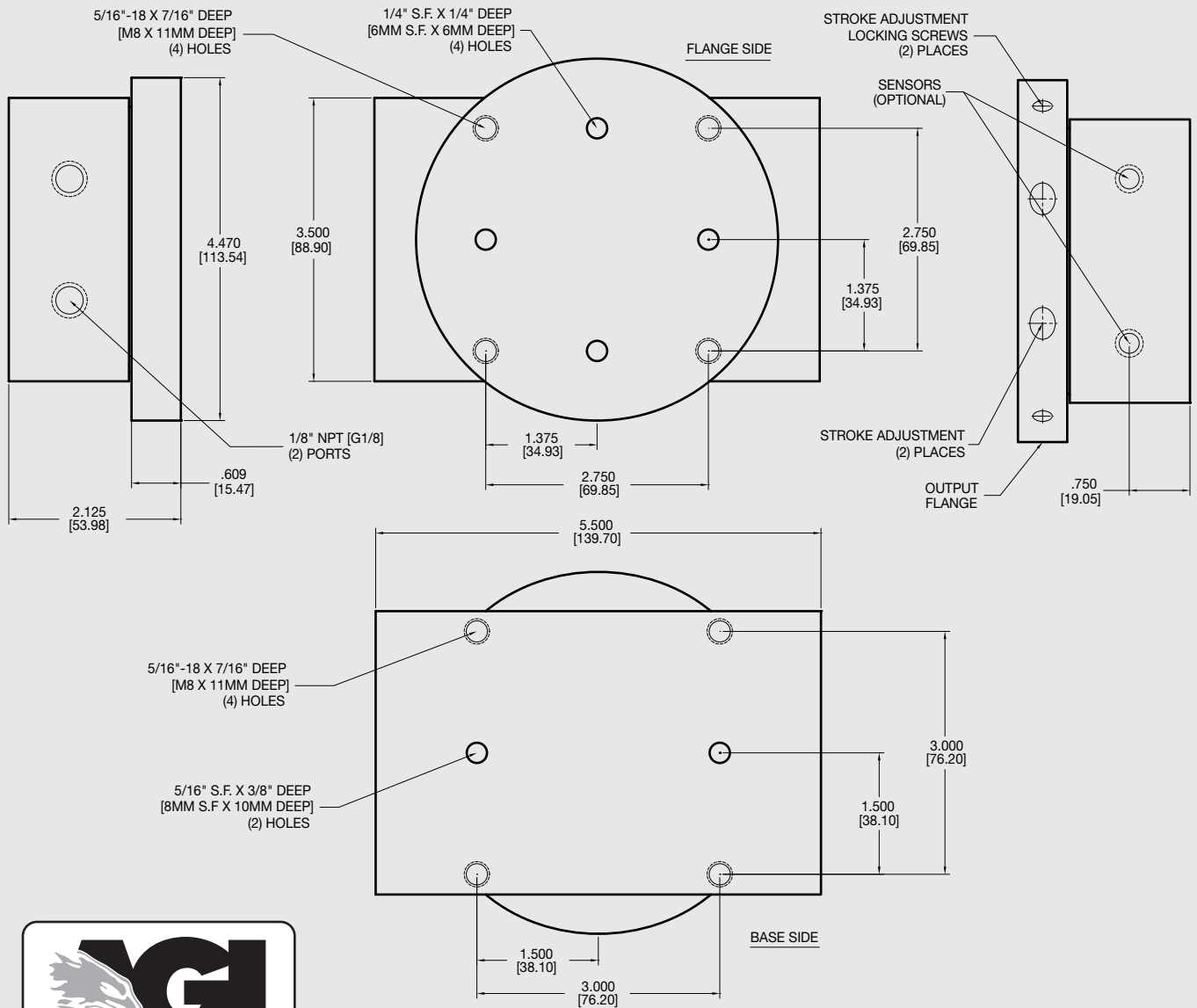

Unless noted, all tolerances are as indicated here:



All Dowel Holes are SF (Slip Fit) Locational Tolerance $\pm .0005"$ [.013mm]



Metric Threads Course Pitch

Imperial:
Inch 0.00 = $\pm .01$
0.000 = $\pm .005$
0.0000 = $\pm .0005$

Metric: [0.] = $\pm .25$
[0.0] = $\pm .13$
[0.00] = $\pm .013$

AGR-4 Rotary Actuator

Low Profile, Zero Backlash, Optional Rotary Manifold

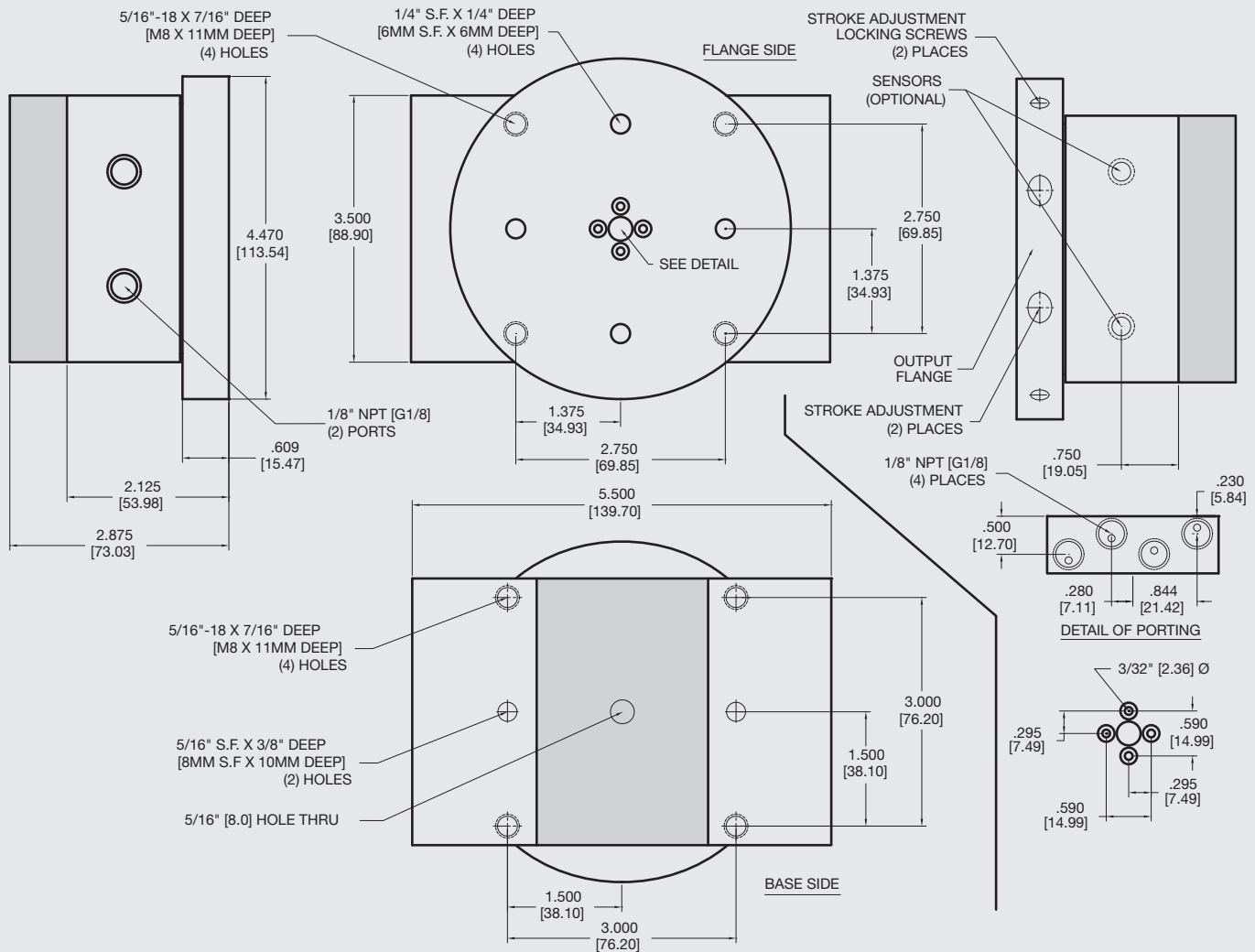

-M option
Rotary Manifold shown shaded

Unless noted, all tolerances are as indicated here:



All Dowel Holes are SF (Slip Fit) Locational Tolerance ± .0005" [0.13mm]



Metric Threads Course Pitch

Imperial: 0.00 = ±.01
Inch 0.000 = ±.005
0.0000 = ±.0005

Metric: [0.] = ±.25
[mm] [0.0] = ±.13
[0.00] = ±.013

AGR-4 Rotary Actuator

Low Profile, Zero Backlash, Optional Rotary Manifold

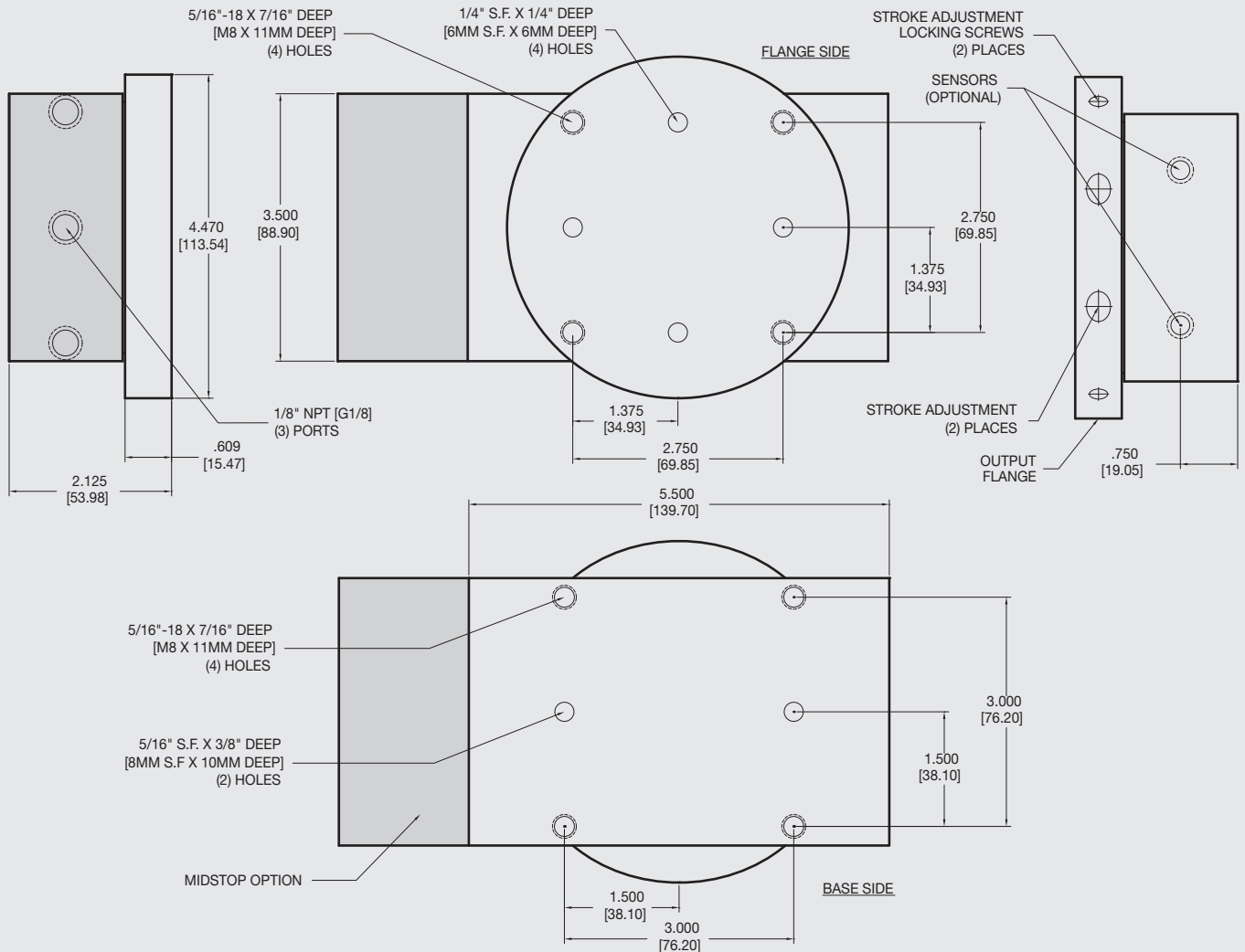

-S option
Mid-Stop shown shaded

Unless noted, all tolerances are as indicated here:



All Dowel Holes are SF (Slip Fit) Locational Tolerance $\pm .0005"$ [.013mm]



Metric Threads Course Pitch

Imperial:
Inch

0.00 = $\pm .01$
0.000 = $\pm .005$
0.0000 = $\pm .0005$

Metric: [0.] = $\pm .25$
[mm] [0.0] = $\pm .13$
[0.00] = $\pm .013$