



LOAD LIMITER

LOW PROFILE -VARIABLE TRIP POINTS

AGO-6



Download 2 & 3D CAD Drawings:
www.AGI-AUTOMATION.com

DIMENSIONAL DRAWING

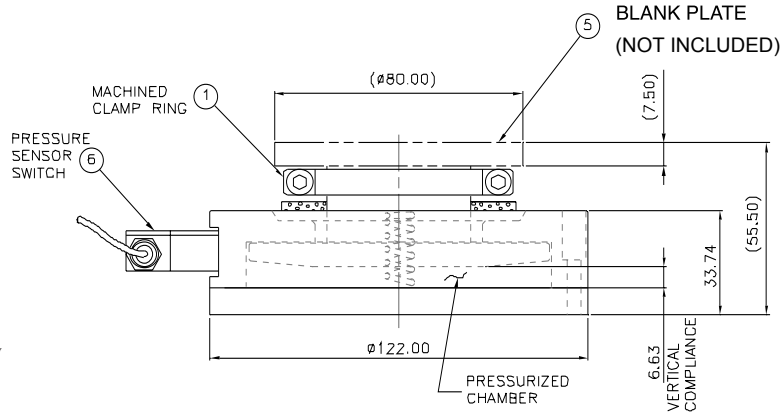

SPECIFICATIONS

- Design** Non-resistive compliancy upon impact
- Rotation Range** 360° unlimited torsional rotation
- Torque** (Continuously Variable)
 - Max. Breakaway Mom. M_x .. 566 in-lb
 - Max. Breakaway Mom. M_y .. 566 in-lb
 - Max. Breakaway Mom. M_z .. 749 in-lb
 - Min/Max Breakaway
 - Compressive C 113/676 lb
- Avg. Response Time** ... 4 - 8 ms
- Pressure Range**
 - Low 14 psi
 - High 90 psi
- Temperature Range**
 - Low -32°F
 - High 212°F
- Repeatability**
 - X and Y..... ± 0.001 in
 - Z ± 0.0005 in
 - Rotational ± 0.024°
- Compliance Angle** (x,y) ± 5°
- Axial Compliance (Z+)** .. ± 0.265 in
- Switch Description** 3 amps; 24 VDC; High-reliability aircraft snap acting type
- Material** High-strength; Hard-coated aluminum alloys; Stainless Steel
- Weight** 2.9 lb

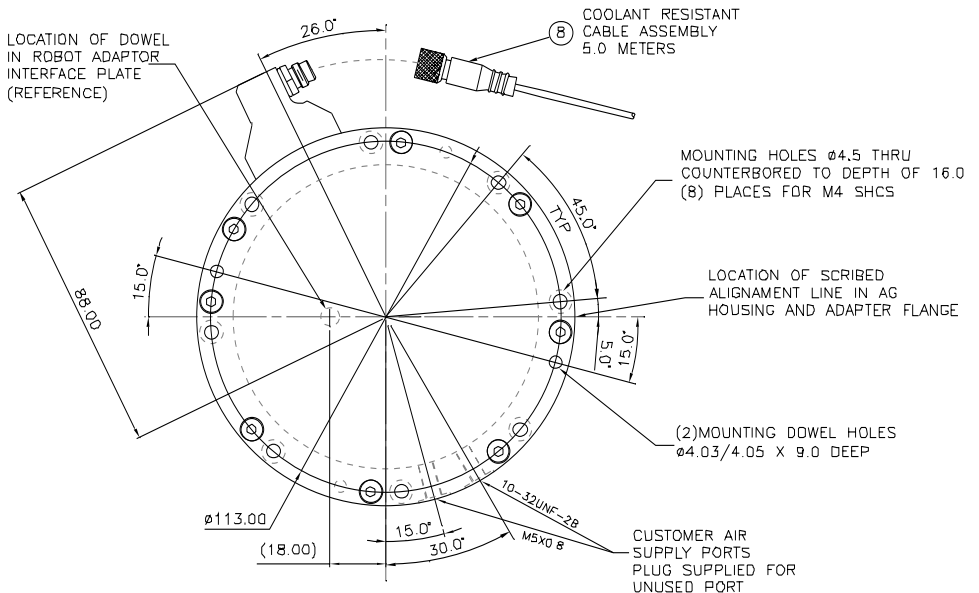

NOTE: Dimensions are metric.

LOADING INFORMATION

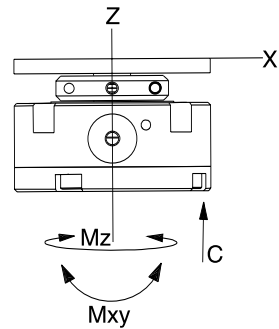

BREAKAWAY MOMENT

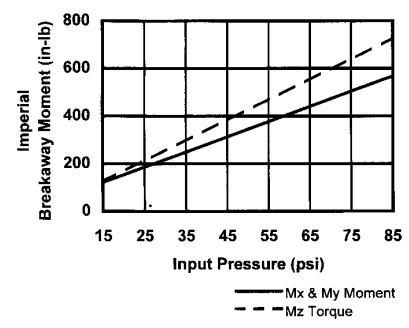

**TO ORDER OR FOR MORE INFORMATION, PLEASE CALL (203) 459-8345, FAX (203) 452-5943
VISIT OUR WEBSITE AT: www.AGI-AUTOMATION.com**