

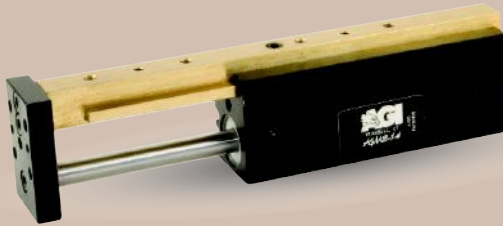

# AGMS-1-4 Mini Powered Slide

## Built-In Air Cylinder



### FEATURES AND BENEFITS

- T-Slot bearing support for the carriage and end plate offers superior load bearing performance throughout the stroke.
- Standard built-in stroke adjustment and stroke lock for precise, repetitive operation.
- Compact, lightweight unit with built-in cylinder.
- Piston seals are U-CUP type for long service life.
- Hall Effect sensors are available to monitor stroke position.
- Multiple mounting surfaces on the body and endplate with threaded and counterbored holes for easy mounting choices.

### SPECIFICATIONS

Design: Built-in air cylinder  
T-slot slide

Stroke: 2.0 in [50.8 mm]

#### Thrust Force @ 80 PSI [5.5 BAR]

Extended: 15 lbs [66.7 N]  
Retract: 13 lbs [57.8 N]

Recommended Speed:

2-12 in/sec  
[0.5-.3m/sec]

Pressure Range:

Low/High 20-120 PSI [1.4-8 BAR]

Temperature Range:

Low/High -20°/150°F [-28°/80°C]

Side Play:

± 0.001 [0.03 mm]

Maximum Payload:

18 lbs [81.6 kg]

Material: High Strength, Aluminum Alloys,  
Bronze

Weight:

5 oz [142 g]

Piston Diameter:

.50 in [12.7 mm]

January 2009 - PATENTED Made in the USA

### MAXIMUM FORCES & MOMENTS

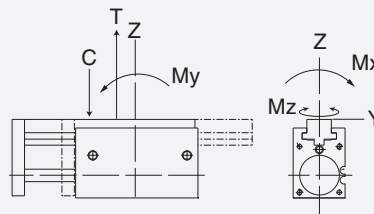

	Static	Dynamic
Max Tensile T	130 lbs [578 N]	55 lbs [244 N]
Max Compressive C	130 lbs [578 N]	55 lbs [244 N]
Max Moment $M_x$	110 in/lb [12.5 Nm]	50 in/lb [6.7 Nm]
Max Moment $M_y$	110 in/lb [12.5 Nm]	50 in/lb [6.7 Nm]
Max Moment $M_z$	110 in/lb [12.5 Nm]	50 in/lb [6.7 Nm]

### HOW TO ORDER

When ordering, please specify:  
Design/Model Number and Options.

#### DESIGN/MODEL

AGMS-1-1  
AGMS-1-2  
AGMS-1-3  
AGMS-1-4

#### TYPE

M = METRIC  
= IMPERIAL

#### SENSOR TYPE

1 = NPN  
2 = PNP

**AGMS-1-4** **M** - **3** - **1** - **1**

#### SENSOR OPTIONS\*

1 = LEFT  
2 = RIGHT  
3 = BOTH

#### SENSOR CONNECTOR

1 = POTTED  
2 = QUICK DISCONNECT  
3 = QUICK DISCONNECT  
WITH RIGHT ANGLE

\* NOTE: Hall Effect sensors – Potted or Quick disconnect.

Sensor Part # SHN01, SHP01, SHNQ3, SHPQ3

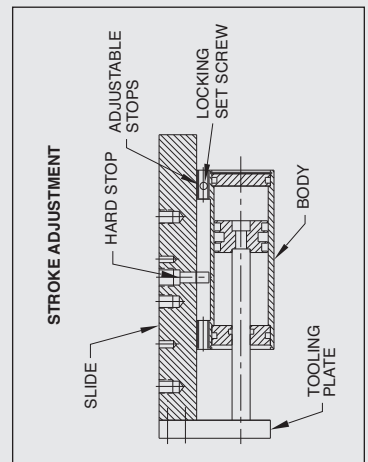
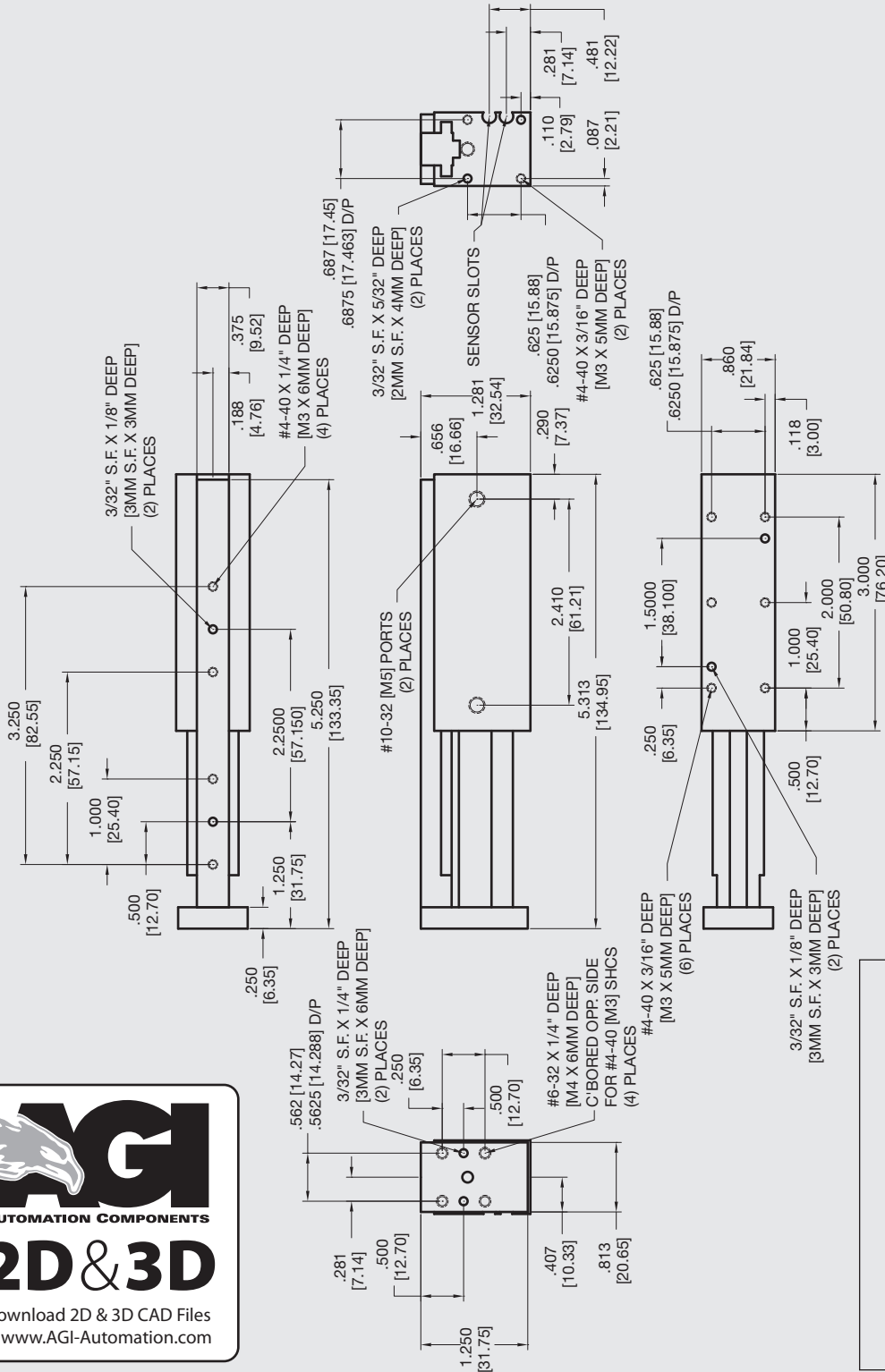

**Unless noted, all tolerances are as indicated here:**



All Dowel Holes are SF (Slip Fit) Locational Tolerance  $\pm .0005$  [0.13mm]



Metric Threads Course Pitch

**Imperial:**  
Inch 0.00 =  $\pm .01$   
0.000 =  $\pm .005$   
0.0000 =  $\pm .0005$

**Metric:** [0.] =  $\pm .25$   
[mm] [0.0] =  $\pm .13$   
[0.00] =  $\pm .013$