



AGP-23 Three Jaw Parallel Gripper

T-Slot Bearing Series



FEATURES AND BENEFITS

- Jaws are T-Slot bearing supported to prevent jaw breakage and offer superior load bearing performance.
- High gripping force to weight ratio.
- Compact design with long stroke.
- True parallel jaw motion for easy tooling.
- Units are permanently lubricated for non-lube air operation, allowing for compliance with OSHA regulations.
- Hall effect sensors are available to monitor open and closed position of the jaws.
- AGP is fully field repairable for cost savings and minimum down time.
- Multiple mounting surfaces on jaw for easy tooling.
- Optional stripper plate ensures part preload in location upon release.

SPECIFICATIONS

Design: Parallel, Double Acting, Synchronized Jaws

Stroke: .30 in [7.6mm]

Gripping Force @ 80 PSI [5.5 BAR]

Closing: 29 lbs [129 N]

Opening: 26 lbs [115 N]

Time:

Close: 0.22 sec [0.22 sec]

Open: 0.22 sec [0.22 sec]

Pressure Range:

Low/High 30-120 PSI [2-8 BAR]

Temperature Range:

Low/High -20°/180°F [-28°/80°C]

Side Play: ± 0.001 [.03 mm]

Repeatability from Center: ± 0.002 [.06 mm]

Loading Capacity:

	Static	Dynamic
Max Tensile T	300 lbs [1300 N]	100 lbs [444 N]
Max Compressive C	300 lbs [1300 N]	100 lbs [444 N]

Max Moment M_x 250 in/lb [2.8 Nm] 75 in/lb [8.5 Nm]

Max Moment M_y 250 in/lb [2.8 Nm] 75 in/lb [8.5 Nm]

Max Moment M_z 150 in/lb [17 Nm] 75 in/lb [8.5 Nm]

Material: High Strength, Hard Coated aluminum bronze alloys, Steel

Weight: 9 oz [255 g]

Piston Diameter: 1.25 in [32 mm]

January 2009 - PATENTED Made in the USA

HOLDING FORCES CHART

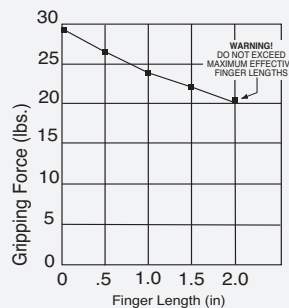

WARNING! Do not exceed tooling jaw length. See Chart above.

LOADING INFORMATION

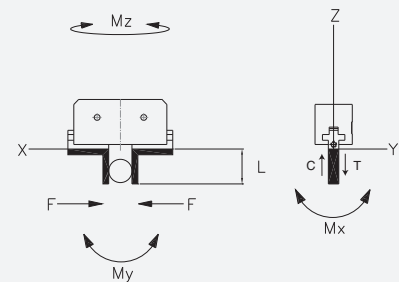

LOOK! More Technical specifications for sensors on "Sensors Accessories" page.

HOW TO ORDER

When ordering, please specify: Design/Model Number and Options.

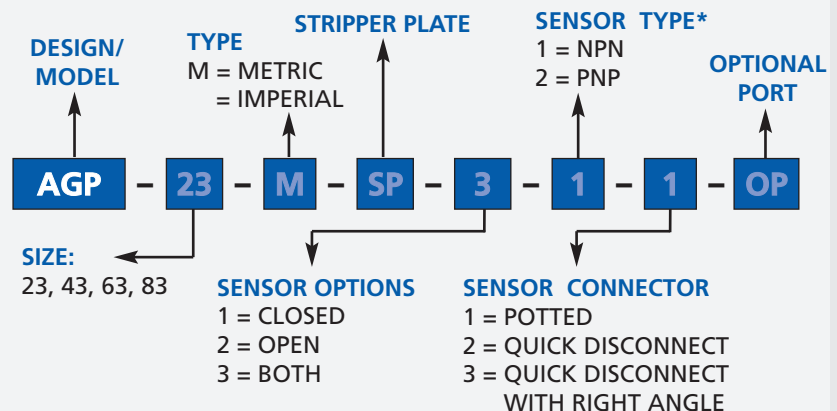

* NOTE: Hall Effect 4mm dia., 5-24 VDC, 22 mA and comes with 2 meter cable.

Sensor Part # SHN02, SHNQ4, SHP02, SHPQ4

AGP-23 Three Jaw Parallel Gripper

T-Slot Bearing Series

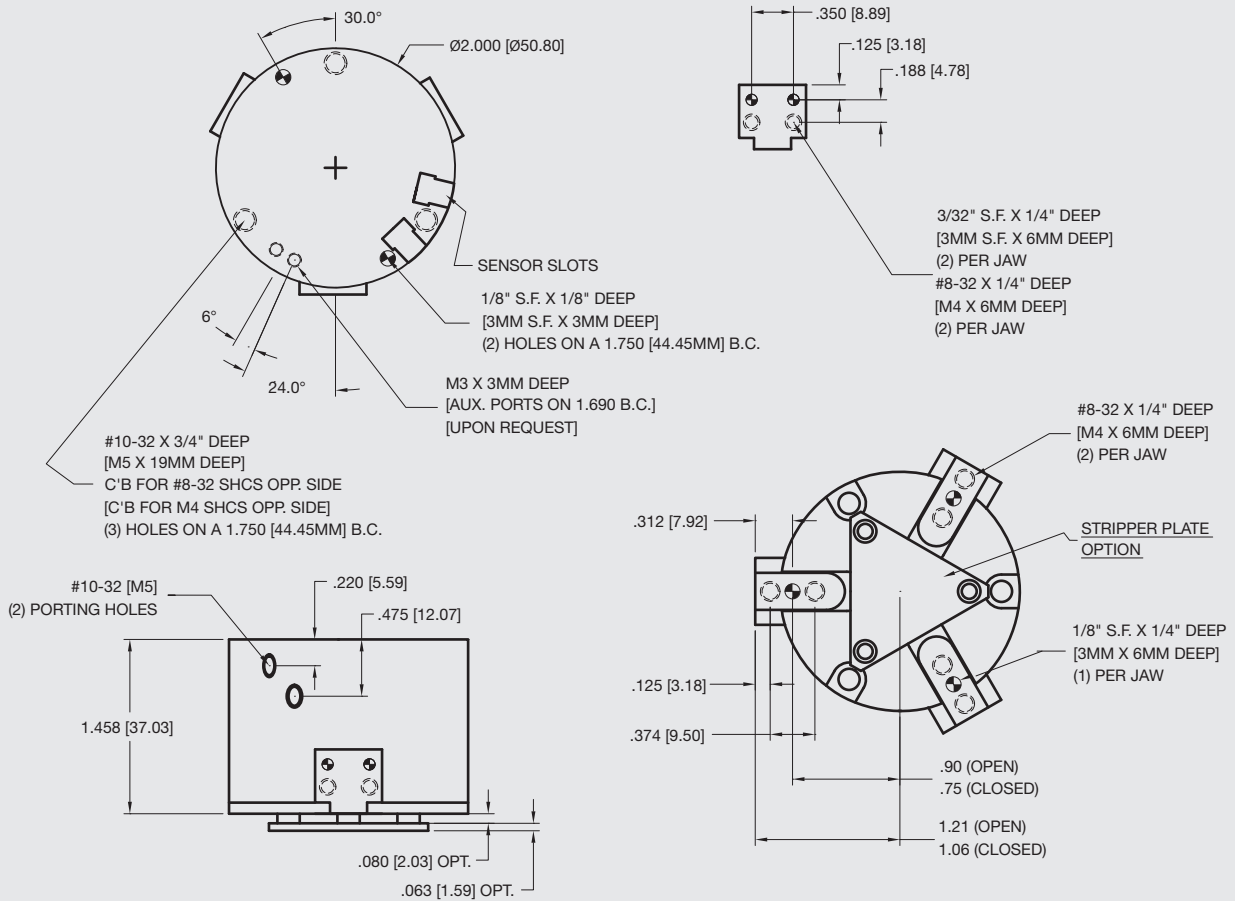

Unless noted, all tolerances are as indicated here:



All Dowel Holes are SF (Slip Fit) Locational Tolerance $\pm .0005"$ [.013mm]



Metric Threads Course Pitch

Imperial:
Inch

0.00 = $\pm .01$
0.000 = $\pm .005$
0.0000 = $\pm .0005$

Metric:
[mm]
[0.] = $\pm .25$
[0.0] = $\pm .13$
[0.00] = $\pm .013$